

Standard Model Digital Force Gauge ZTS Series

- Fast sampling for both Peak Values and Continuous Data, achieving high reproducibility
- Clear OLED display with a variety of significant capabilities
- Measurement benefit increased by external output and practical functions
- Allows easy Data acquisition and management with the included software



ZTS-2N~1000N



High Load Model
ZTS-2500N~5000N



Product Package with
included Accessories

[Evolution to the Next Series]

Next Series is a generic term for IMADA measurement devices with upgraded functions, performances with the essential modifications. The devices enable to install additional functions from the user support site, IMADA-Connected. On the website, related data such as software and instruction manuals can also be downloaded. New Series: ZTS Series Firmware Ver.5 or later.

New Features

-Increased measurement stability achieved from further noise reduction to the measurement circuit.

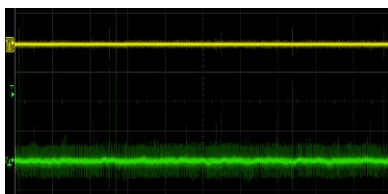

Analog output comparison
Yellow: Next series/Green: Old Model

-Force gauge program (firmware) online updates available.

-Various software and additional functions downloadable to increase the measurement conveniences.



IMADA-Connected
(<https://www.imada-connected.com/>)

[Features]

Fast sampling for both Peak Values and Continuous Data, achieving high reproducibility

High-speed sampling of up to 2000 times/second updates measured values for more accurate peak-value readings.
By using the optional software sold separately (refer to P.5), graphed as continuous Data with the sampling data of up to 2000 times/second, and even frictional Load changes visualized and evaluated.

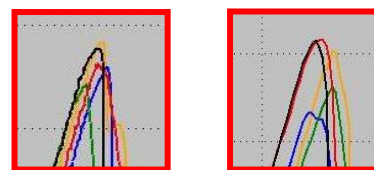

Destructive test comparison of the same sample by sampling speed: -
-Left Sampling speed 2000Hz
-Right Sampling speed 100Hz
The less variation shown in the left results

*The Test Results vary depending on the sample and measurement conditions.

Clear OLED display with a variety of significant capabilities

The OLED provides excellent contrast and high visibility, which reduces errors in reading measurement results.
In addition, the display screen can be divided into three sections, allowing to customize the display contents for liking, such as calendar, bar graph and Comparator setting values on the top and bottom.
In addition, it has various display capabilities such as a multi-language setting menu and overload warning display.

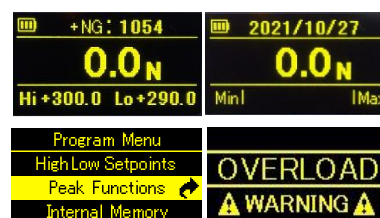

Measurement benefit increased by external output and practical functions

By providing a wide range of data output options such as USB, wireless, serial communication, and analog output, it can be used in a wide range of situations from data management on a PC to interlocking with various devices.
The system used to control external devices, such as stopping the machine at a specified load value, or to create an inspection device linked to a work process in order to improve the efficiency of the inspection process.



The warning light and other devices may be used to detect measurement abnormalities.

Allows easy Data acquisition and management with the included software

USB Cable and software *Force Logger* included in the original package to proceed with the data management when purchased.
With the software, displayed values and internal memory data stored in a force gauge and continuous data acquired (10 data per second).
It also allows to change and save the Force-Gauge settings from facilitating the management of measurement conditions. (Please refer to P.4 for the system requirements).



[Specifications of ZTS series]

Model	ZTS
Feature	Standard Model with high functionality and usability.
Accuracy	+/-0.2%F.S.+/-1digit
Measurement Unit	N, kgf, lbf (*1)
Display	4-digit Organic EL
Display update	16 / sec
Sampling Rate	2000 data / sec at maximum
Battery	6.5 hours (2 hours for re-charging)
Safe overload rating	Approx.200%F.S.
Operating environment	Temperature: 0 to +40 degree Celsius, Humidity: 20 to 80%RH
Function	Customized display (header and footer), Peak hold (tension and compression), Internal 1000 points data memory, Comparator (judgment of OK or NG), Reversible display, Sign inversion, Zero clear timer, +NG alarm, Off timer (auto power off), Dumping, Time display, Setting lock
Output	USB, RS232C / ± 2 VDC analog output (D/A), Comparator 3 steps (-NG/OK/+NG), Overload alarm
Overload warning	Approx.110%F.S. (Warning message and alarm)
External connecting switch	Power ON / OFF / Send and Hold / Zero reset / Peak and Real-time switching
Weight	From 2N to 1000N Model: Approx.490g (*2) 2500N, 5000N: Approx.1100g (*2)
Dimensions	Please refer to dimensions.
Accessory	AC adapter, Inspection certificate, CD driver (including data logging software), Attachments (The set of attachments varies according to range.), Handles (only for 2500N/5000N range), USB cable, Carrying case.

(*1) The measurement Unit: mN displayed for models of 5N or less, and kN displayed for models of 1000N or more.
In addition, possible to display the unit kg (g: 5N or less range) as a conversion value.

(*2) The Weight differs according to the Model range.

[Option]

Option	Description	Model
Analog output: RAW	The raw analog data is output without digital processing	-AN

-For this option, add the code (-AN) to the end of the Product Model Number. (Example: ZTS-500N-AN)

-This option requires a dedicated cable CB-118 sold separately.

-Data responsiveness is higher than standard analog output (D / A), with the disadvantages of Zero reset disable and high noise components.

[ZTS series models]

Model	Capacity	Display	Resolution	Thread	Included attachment
ZTS-2N	2N	2.000N	0.001N (1mN)	M6	A1 - A8
ZTS-5N	5N	5.000N	0.001N (1mN)		
ZTS-20N	20N	20.00N	0.01N		
ZTS-50N	50N	50.00N	0.01N		
ZTS-100N	100N	100.0N	0.1N		S1 - S8
ZTS-200N	200N	200.0N	0.1N		
ZTS-500N	500N	500.0N	0.1N		
ZTS-1000N	1000N	1000N	1N (0.001kN)	M10	RS1, S2 - S8
ZTS-2500N	2500N	2500N	1N (0.001kN)		B1 - B8
ZTS-5000N	5000N	5000N	1N (0.001kN)		

[Included Accessories]

-Force Logger: Data Acquisition Graphing Software

	<p>Main Functions</p> <ul style="list-style-type: none"> -Easy Importing of the Measurement Data -Display Acquired Data Value Statistics: -Maximum / Minimum / Average Values. -Data saved in CSV format -Continuous Data acquisition up to 10 times per second. -Force-Gauge Function Settings. <p>Operating environment</p> <ul style="list-style-type: none"> - OS: 8.1/10/11 - Hardware: CPU 1GHz or more recommended Memory 2GB or more recommended Hard disk 10GB (Data storage area) or more - Platform: .NET Framework4.8 or later
--	--

-Standard Force-Gauge Attachments (Accessories) : For Axis size M6
Force-Gauge Capacity 100N or less : A-Types (Aluminum)
Force-Gauge Capacity 200N -1000N : S-Types (Steel)





A-1/S-1 *SR-1	A-2/S-2	A-3/S-3	A-4/S-4	A-5/S-5	A-6/S-6	A-7/S-7	A-8/S-8
Small Hook	Disk Tip	Conical Tip	Chisel Tip	Notched Tip	Extension Rod	Large Hook	Y Hook
Tension	Compression	Compression	Compression	Compression	Axis Length Adjustment	Tension	Tension

*Small Hook S-1 for Capacity 200N – 500N, and SR-1 for Capacity 1000N.

-High-Capacity Force Gauge Attachments (Accessories) : For Axis size M10
Force-Gauge Ranges 2500N-5000N: B-Types (Steel)

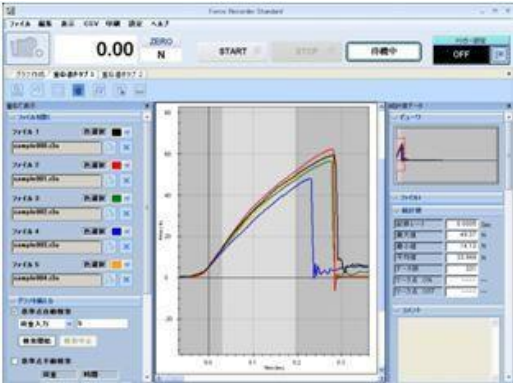
B-1	B-2	B-3	B-4	B-5	B-6	B-7	B-8
Small Hook	Disk Tip	Conical Tip	Chisel Tip	Notched Tip	Extension Rod	Handle	Mounting Bolts
Tension	Compression	Compression	Compression	Compression	Axis Length Adjustment	For High Capacity Models	For High Capacity Models

[Related Products]



Graphing and Data Acquisition Software: Force Recorder Series		
 <p>The Standard Version Image</p>	<ul style="list-style-type: none"> -High-speed USB communication (up to 2000 times/second or 1000 times/second for Plus version) enables graphing for minimal load changes. -Up to 5 graphs overlaid for comparison with the Standard and Professional versions. (10 graphs with Plus version) -Notes added for record keeping of the measurements -For Data managing and reporting, Graphs pasted as the Image Data. <p>*4 Software versions available for different requirements, (Force Recorder Light / Standard / Professional and Plus) Please refer to the individual Manuals for details.</p>	
Wireless Data Transmit System: WL01 Series		
 <p>WL01-USB and WL01-ADP</p>	<ul style="list-style-type: none"> -Wireless communication allows the Data received from remote locations. -The Data reception detection and interference prevention functions support stable communication. -The communication format opened to the public and incorporated into the available facilities possible. <p>Note</p> <ul style="list-style-type: none"> -Compatible with firmware Ver3.10 or later. -Restrictions on the countries and regions for use. -Please refer to [Wireless System] Specifications for details. 	
Handle FOH-1 (*1)	Hand Grip Belt HGB-1	Rechargeable Battery: BP-308
	 <p>For max. capacity 200N</p>	
Attach to the Force Gauge for Firm-hold and stable operation with both hands	To hold and stabilize the Force-Gauge for single-hand operation	Rechargeable Battery for replacement

For High Capacity Models ZTS-2500N / 5000N, dedicated Handles included in the original package for Firm-hold.
(*1) For the Middle to Low Capacity Only.

[Cables]

Models	Names	Descriptions
CB-108	Analog Cable	To connect to a multi-meter oscilloscope.
CB-118	Analog cable (For -AN option)	To connect to a multi-meter oscilloscope.
CB-208	RS232C Cable	To connect to a PC having its system
CB-508	Test stand option cable (For MX Series)	To connect to a test stand to enable force control or overload prevention functions.
CB-528	Test stand option Cable (MX2 / MX Series)	To connect to a test stand to enable force control or overload prevention functions.
CB-908	Open End Connection Cable	Output cable for loose wire 37 pin (Useful for connection with unique equipment.)

[Other Options]

Force gauge ZTA Series	Sensor-separate force gauge ZTS/ZTA Series	eZ-Connect Series: Sensor-interchangeable Amplifier eZT
		
<p>High-Functional Model with displacement input/output function added to ZTS series.</p>	<p>External sensor type for use in the restricted environment (narrow space etc.) or installing into the specific facilities.</p>	<p>The amplifier enables to connect to the various eZ-Connect Series Load Cells.</p>

[Dimensions: ~1000N]

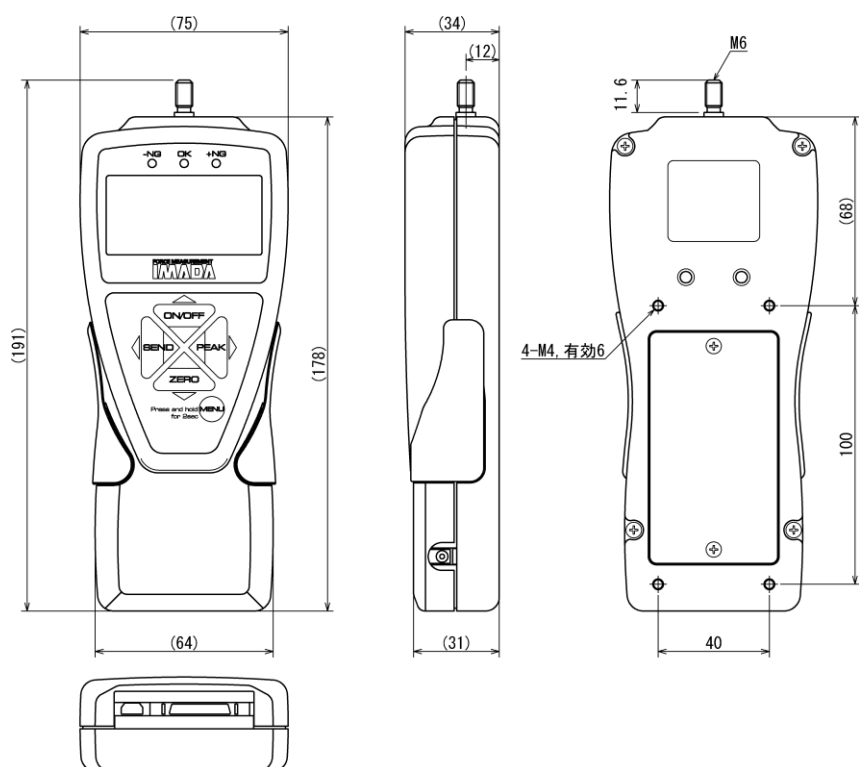

Unit: mm

[Dimensions: 2500N~5000N]

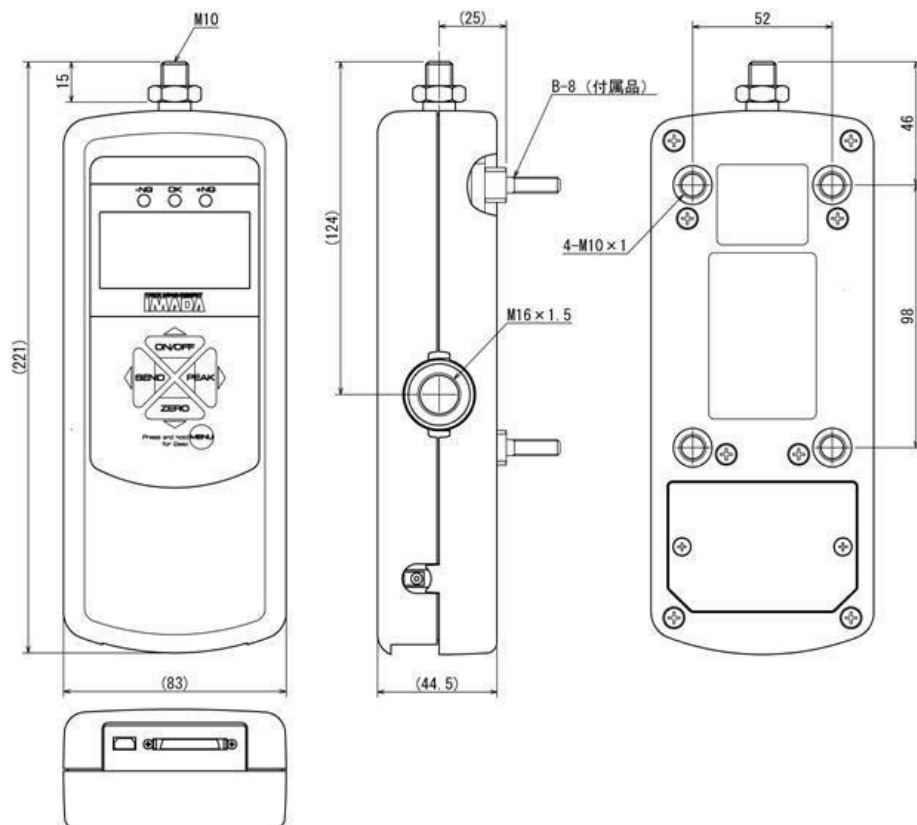

Unit: mm

[ISO Calibration Service and Calibration Certificate]

- We are the accredited ISO / IEC 17025: 2017 Calibration Organization with the in-house Calibration Service facility.
- The Calibration Service and Issuing of the Calibration Certificates available at cost.
- For further information, please kindly contact the local authorized distributor or us.

[Caution]

- Information in this document is subject to change without prior notice.
- This product is designed for force measurement purposes only.
- Do not copy and use this content without authorization.
- Do not apply force more than its capacity and from incorrect direction to the measuring shaft.
- Note that the allowable values may vary slightly depending on the unit selected on display. Please contact us for more information and details.

IMADA CO., LTD.

99, Jinnoshinden-Cho, Aza, Kanowari, Toyohashi,
Aichi 441-8077, JAPAN
Tel: +81-(0)532-33-3288
Fax: +81-(0)532-33-3866
E-mail: info@forcegauge.net
Website: <https://www.forcegauge.net/en/>



Visit our website for more information on wide product specifications, measurement applications and videos.